



HFM

Hyosung Turbine Type Multi-Stage Pump



Springs of Living Water



G

소방 규정	G 01
용도 Application	G 02
특징 Features	G 02
호칭 Model Designation	G 02
표준 사양 Standard Specification	G 02
선정도 Selection Chart	G 03
조립 단면도 Sectional Drawing	G 04
외형도 & 외형 치수표 Outline Drawing & Dimension [HFM 40]	G 07
외형도 & 외형 치수표 Outline Drawing & Dimension [HFM 50/65/80/100/125/150/200]	G 08

소방 규정에 따른 펌프의 선정 기준

[옥내소화전설비의 화재안전기준 NFSC 102 제6조 8항]

- ① 펌프의 성능은 체절 운전 시, 정격 토출압력의 140%를 초과해서는 안된다.
- ② 정격 토출유량의 150% 유량에서 토출압력은 정격 토출압력의 65% 이상이 되어야 한다.

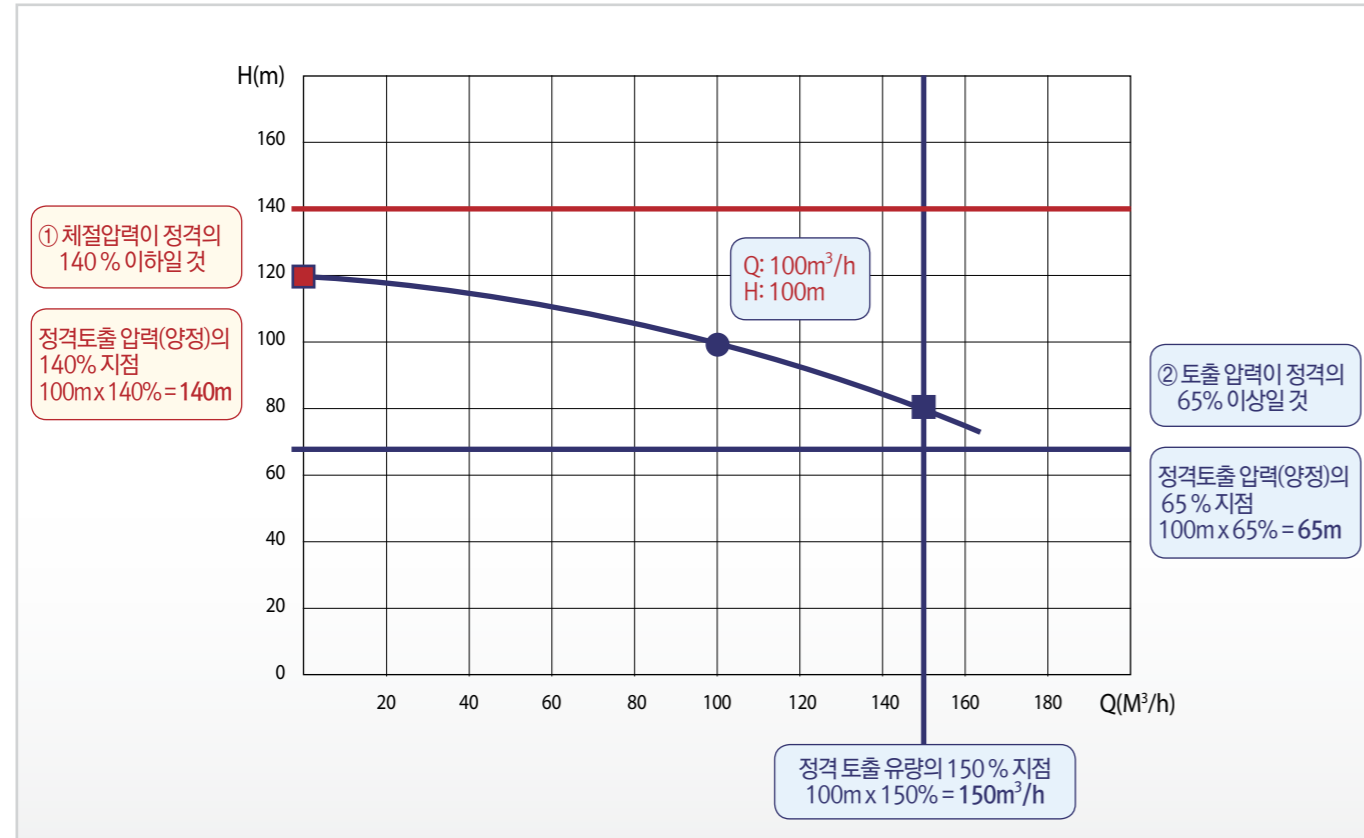

[정격 토출유량(Q) = 100m³/h, 정격 토출압력(H) = 100m 인 펌프의 선정 기준]

소방 규정에 따른 펌프 재질 선정 기준 [소방청고시 제2021-12호]

스프링클러설비의 화재안전기준 NFSC 103 제5조 17항] <신설 2021. 1. 29>
가압송수장치는 부식 등으로 인한 펌프의 고착을 방지할 수 있도록 다음 각 목의 기준에 적합한 것으로 할 것.

- 가. 임펠러는 청동 또는 스테인리스 등 부식에 강한 재질을 사용할 것.
- 나. 펌프축은 스테인리스 등 부식에 강한 재질을 사용할 것.

소방 규정 위반에 따른 과태료 [법률 제17007호]

제 9조 ① 특정소방대상물의 관계인은 대통령령으로 정하는 소방시설을 화재안전기준에 따라 설치 또는 유지·관리하여야 한다. <개정 2014. 1. 7.>

제 53조(과태료) ① 다음 각 호의 어느 하나에 해당하는 자에게는 300만원 이하의 과태료를 부과한다. <신설 2016.1.27., 2020.6.9.>
1. 제9조제1항 전단의 화재안전기준을 위반하여 소방시설을 설치 또는 유지·관리한 자

용도 Application



특징 Features

- 소형 경량의 다단 터빈 고압 원심펌프로서 우수한 설계와 제조기술로 저진동, 저소음, 고효율 구현
 - 고속회전에서도 안전하며, 고효율을 발휘할 수 있도록 설계
 - 표준화 및 시리즈화(Series)하여 부품의 호환성을 극대화시킨 구조
 - 소방펌프 전용 하이드로 적용으로 고효율 및 경량화 구현
 - 개정 소방 법규를 만족하는 재질 및 구조 적용
- Compact and lightweight high pressure multi-stage centrifugal pump through excellent manufacturing technology, simple and unique design for high efficiency and low vibration and noise
 - Safe and high efficiency design in a high speed rotating condition
 - Standardization with high compatible of component
 - High efficiency and light weight by developing new hydro for fire fighting pump
 - Optimized materials and structures that satisfy the revised firefighting regulations

호칭 Model Designation

HFM 80/4

펌프 모델명
HFM
Model Name

토출구경
80
Discharge Diameter [mm]

단수 [회전차수]
4
Number of Stages
[Number of Impellers]

표준 사양 Standard Specification

액질 Liquid	취급액 온도	Applicable Liquid Temperature	청수 Clean Water (pH 5.8 ~ 8.6) 0 ~ 90°C
유량 / 양정 Capacity / Head			3 ~ 650 m³/h / 10 ~ 380 m
회전방향 Rotation Direction			CW (구동기 측에서 펌프를 바라보았을 때) (From the Motor Side to the Pump)
구경 Diameter	HFM Discharge Dia		40 ~ 200 mm
구조 Structure	회전차 Impeller		클로즈 임펠러 Closed Type Impeller
	축봉타입 Shaft Seal		Packing (테프론 함침 탄소섬유) (Carbonized fibers impregnated with Teflon)
플랜지 Flanges	베어링 Bearing		Ball Bearing, Roller Bearing, Double Row Ball Bearing
	흡입 Suction		KS B 1511 10K, RF, SIDE
카플링 Coupling	토출 Discharge		KS B 1511 20K, RF, TOP
	45kW 이하 Below 45kW		물림형 카플링 Jaw Coupling
재질 Material	55kW 이상 Above 55kW		플랜지 카플링 Flange Coupling
	흡입, 토출케이싱 Suc. & Dis. Casing		GC200
	중간케이싱 Middle Casing		GC200
	회전차 Impeller		SSC13
	축 Shaft		STS304

선택사양 Option

- 접액부 재질 (조립단면도 선택사항 참고)
- 전동기 형식 (요구사항)
- 축봉장치 (Mechanical Seal)
- 카플링 (요구사항)
- 각종 계기류, Drain/Vent 배관 구성
- 흡, 토출 플랜지 방향 및 규격 (별도 문의요망)
- 도장사항 (요구사항)
- Material of the Liquid Contacting Part (Refer to the Specifications in the Sectional Drawing)
- Motor Type (Requirement)
- Shaft Seal (Requirement)
- Coupling (Requirement)
- Instrument, Drain/Vent Piping
- Suction, Discharge Flange Direction and Specification (Contact us)
- Painting (Requirement)

* HFM 모델 구조는 조립단면도 참고할 것.
* GC200 : Cast Iron / SSC13 : Stainless Steel Casting * SM45C : Carbon Steel / STS304 : Stainless Steel

☑ 선정도 Selection Chart

60Hz (1750RPM)

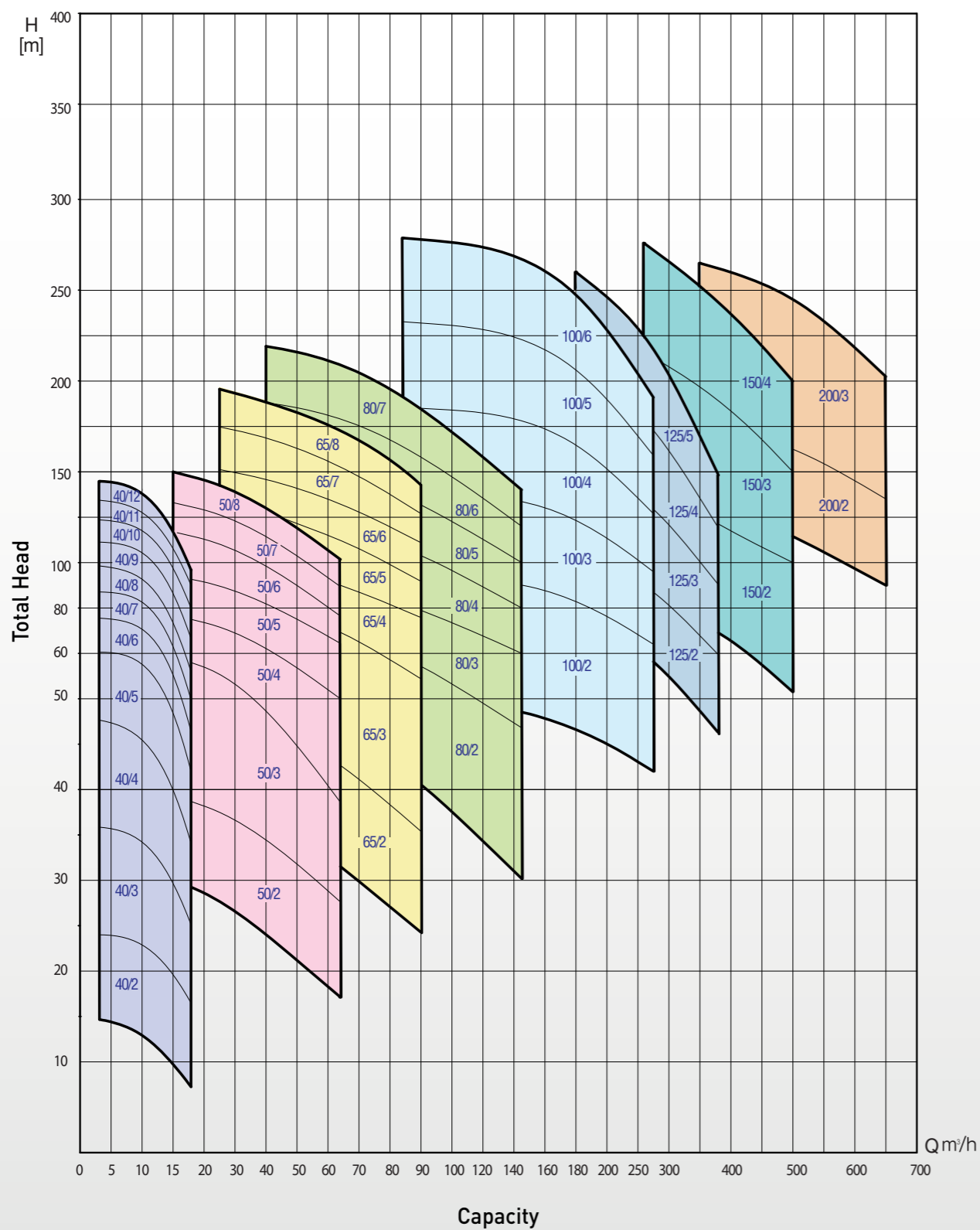

☑ 조립 단면도 Sectional Drawing

[HFM 40]

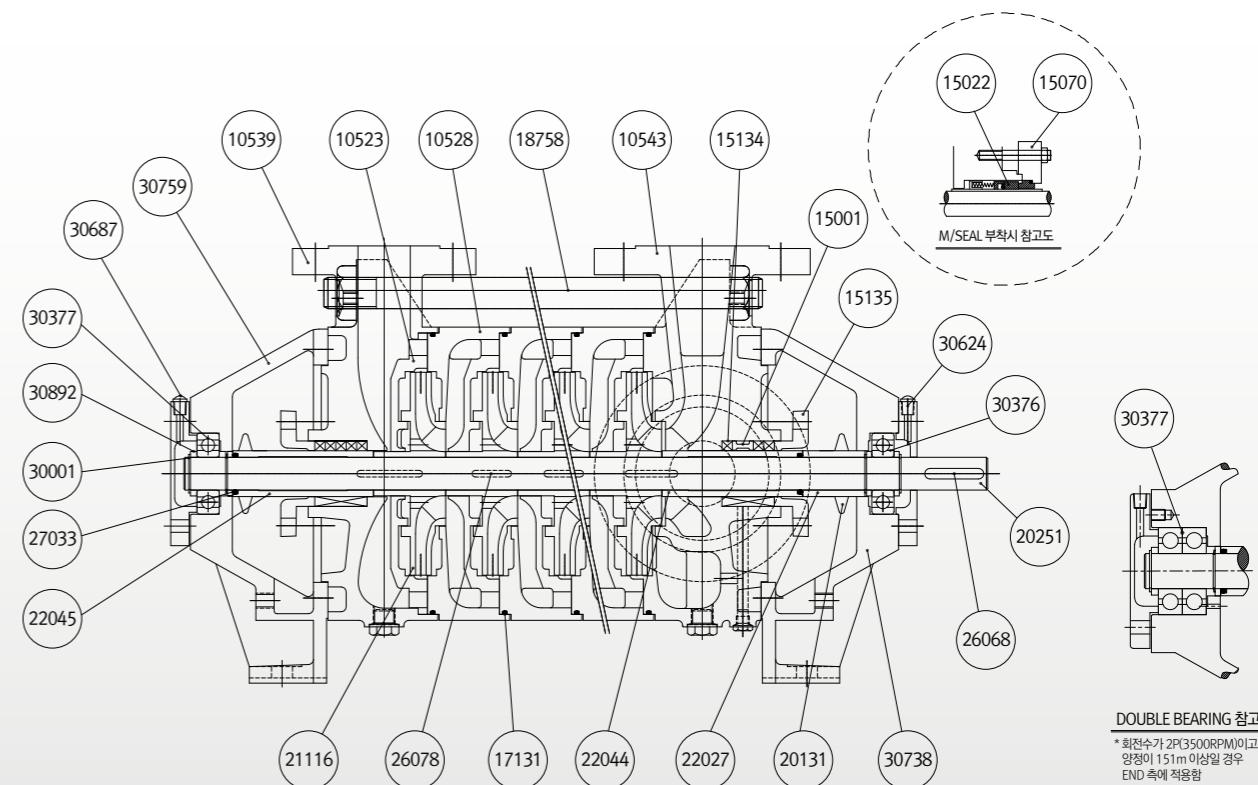

부품번호 Part No.	부품명 Part Name	표준재질 Material	선택사양 Option	부품번호 Part No.	부품명 Part Name	표준재질 Material	선택사양 Option
10523	GUIDE CASING	GC200	SSC13, 14	22027	SPACE SLEEVE	STS304	SM45C, STS316
10528	INTERSTAGE CASING	GC200	SSC13, 14	22044	SHAFT SLEEVE-CP	STS304	SM45C, STS316
10539	DISCHARGE CASING	GC200	SSC13, 14	22045	SHAFT SLEEVE-TH	STS304	SM45C, STS316
10543	SUCTION CASING	GC200	SSC13, 14	26068	KEY-COUPLING	SM45C	-
15001	LANTERN RING	ACETAL	STS304	26078	KEY-IMPELLER	STS304	SM45C, STS316
15022	MECHANICAL SEAL	SiC/CARBON	-	27033	O-RING	NBR	-
15070	SEAL COVER	GC200	SSC13, 14	30001	STOPRING	SK5M	-
15134	PACKING	CARBON FIBER	-	30376	BEARING-CP-BALL	STEEL	-
15135	PACKING RETAINER	GC200	SSC13, 14	30377	BEARING-TH-BALL	STEEL	-
17131	O-RING	NBR	-	30892	SPACER RING	SM45C	-
18758	TIE BOLT	SS275	-	30624	BEARING COVER-CP	GC200	-
20131	PROTECTRING	RUBBER	-	30687	BEARING COVER-TH	GC200	-
20251	SHAFT	STS304	SM45C, STS316	30738	BEARING HOUSING-CP	GC200	-
21116	IMPELLER	SSC13	SSC14	30759	BEARING HOUSING-TH	GC200	-

* CARBON FIBER : Carbonized Fiber Impregnated with PTFE Braided Packing
 * Part No. 15022, 15070 are applicable for M/Seal Option

조립 단면도 Sectional Drawing

[HFM 50/65/80/100]

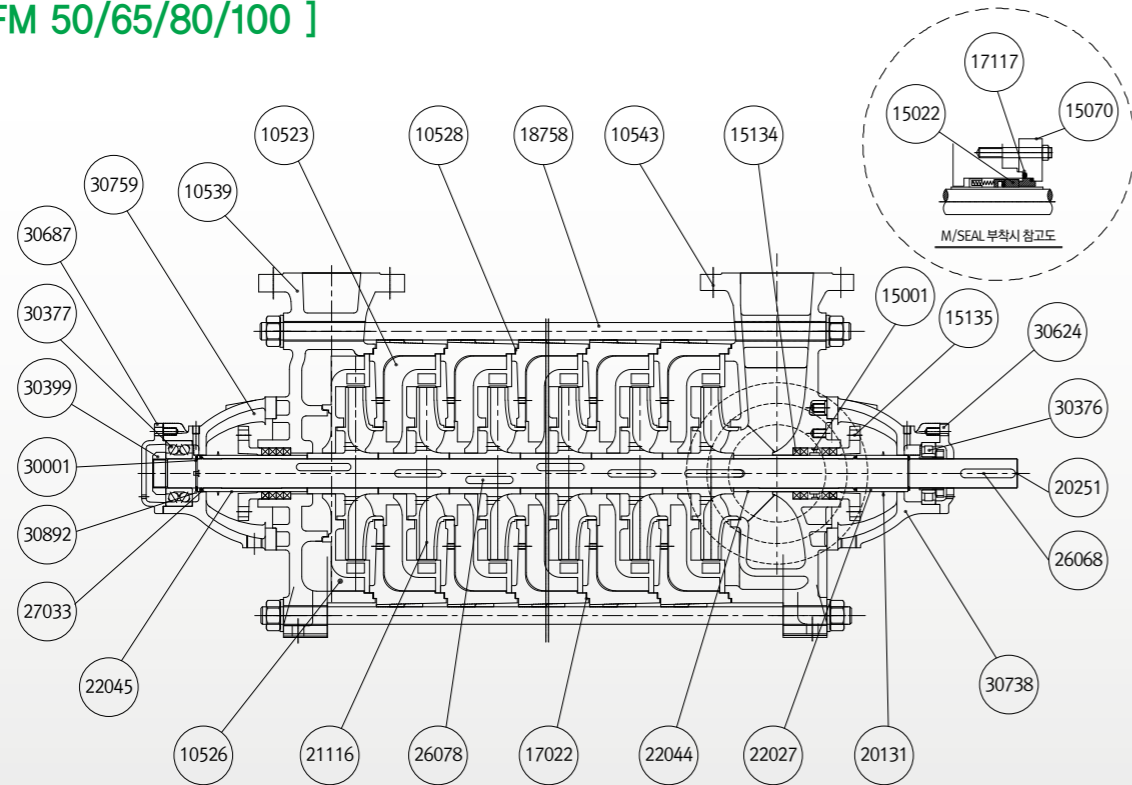

BEARING TYPE

- HFM50 : Ball (CP) / Ball (TH)
- HFM65 : Ball (CP) / Double Row Ball (TH)
- HFM80, 100 : Roller (CP) / Double Row Ball (TH)

[HFM 125/150/200]

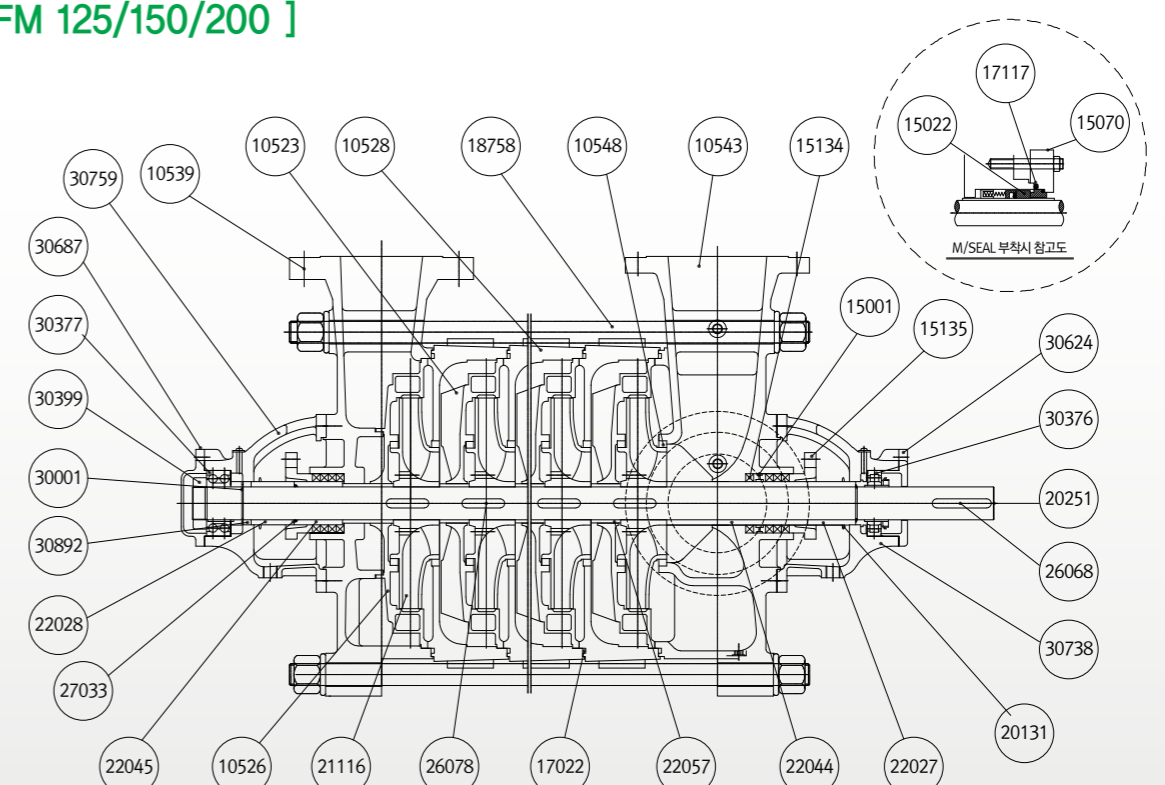

BEARING TYPE

- HFM100, 125, 200 : Roller (CP) Double Row Ball (TH)

부품번호 Part No.	부품명 Part Name	표준재질 Material	선택사양 Option	부품번호 Part No.	부품명 Part Name	표준재질 Material	선택사양 Option
10523	GUIDE CASING	GC200	-	22027	SPACE SLEEVE	STS304	SM45C, STS316
10526	GUIDE CASING-L	GC200	-	22044	SHAFT SLEEVE-CP	STS304	SM45C, STS316
10528	INTERSTAGE CASING	GC200	-	22045	SHAFT SLEEVE-TH	STS304	SM45C, STS316
10539	DISCHARGE CASING	GC200	-	26068	KEY-COUPLING	SM45C	-
10543	SUCTION CASING	GC200	-	26078	KEY-IMPELLER	STS304	SM45C, STS316
15001	LANTERN RING	ACETAL	STS304	27033	O-RING-SLEEVE	NBR	-
15022	MECHANICAL SEAL	SiC/CARBON	-	30001	STOP RING	SK5M	-
15070	SEAL COVER	GC200	SSC13, 14	30376	BEARING-CP(*)	STEEL	-
15134	PACKING	CARBON FIBER	-	30377	BEARING-TH(*)	STEEL	-
15135	PACKING RETAINER	GC200	SSC13, 14	30399	BEARING NUT	SM45C	-
17022	GASKET	NON ASBESTOS	-	30892	SPACERRING	SM45C	-
17117	O-RING-SEAL COVER	NBR	-	30624	BEARING COVER-CP	GC200	-
18758	TIE BOLT	SS275	-	30687	BEARING COVER-TH	GC200	-
20131	PROTECT RING	RUBBER	-	30738	BEARING HOUSING-CP	GC200	-
20251	SHAFT	STS304	SM45C, STS316	30759	BEARING HOUSING-TH	GC200	-
21116	IMPELLER	SSC13	SSC14				

* CARBON FIBER : Carbonized Fiber Impregnated with PTFE Braided Packing
 * Part No. 15022, 15070, 17117 are applicable for M/Seal Option

부품번호 Part No.	부품명 Part Name	표준재질 Material	선택사양 Option	부품번호 Part No.	부품명 Part Name	표준재질 Material	선택사양 Option
10523	GUIDE CASING	GC200	SSC13, 14	22027	SPACE SLEEVE-CP	STS304	SM45C, STS316
10526	GUIDE CASING-L	GC200	SSC13, 14	22028	SPACE SLEEVE-TH	STS304	SM45C, STS316
10528	INTERSTAGE CASING	GC200	SSC13, 14	22044	SHAFT SLEEVE-CP	STS304	SM45C, STS316
10539	DISCHARGE CASING	GC200	SSC13, 14	22045	SHAFT SLEEVE-TH	STS304	SM45C, STS316
10543	SUCTION CASING	GC200	SSC13, 14	22057	INTERSTAGE SLEEVE	STS304	SM45C, STS316
10548	CASING RING	GC200	SSC13, 14	26068	KEY-COUPLING	SM45C	-
15001	LANTERN RING	ACETAL	STS304	26078	KEY-IMPELLER	STS304	SM45C, STS316
15022	MECHANICAL SEAL	SiC/CARBON	-	27033	O-RING-SLEEVE	NBR	-
15070	SEAL COVER	GC200	SSC13, 14	30001	STOP RING	SK5M	-
15134	PACKING	CARBON FIBER	-	30376	BEARING-CP(*)	STEEL	-
15135	PACKING RETAINER	GC200	SSC13, 14	30377	BEARING-TH(*)	STEEL	-
17022	GASKET	NON ASBESTOS	-	30399	BEARING NUT	SM45C	-
17117	O-RING-SEAL COVER	NBR	-	30892	SPACER RING	SM45C	-
18758	TIE BOLT	SS275	-	30624	BEARING COVER-CP	GC200	-
20131	PROTECT RING	RUBBER	-	30687	BEARING COVER-TH	GC200	-
20251	SHAFT	STS304	SM45C, STS316	30738	BEARING HOUSING-CP	GC200	-
21116	IMPELLER	SSC13	SSC14	30759	BEARING HOUSING-TH	GC200	-

* CARBON FIBER : Carbonized Fiber Impregnated with PTFE Braided Packing
 * Part No. 15022, 15070, 17117 are applicable for M/Seal Option
 * Part No. 17117 is applicable for HFM 200 only

HFM

Hyosung Turbine Type Multi-Stage Pump

외형도 & 외형 치수표 Outline Drawing & Dimension

[HFM 40]

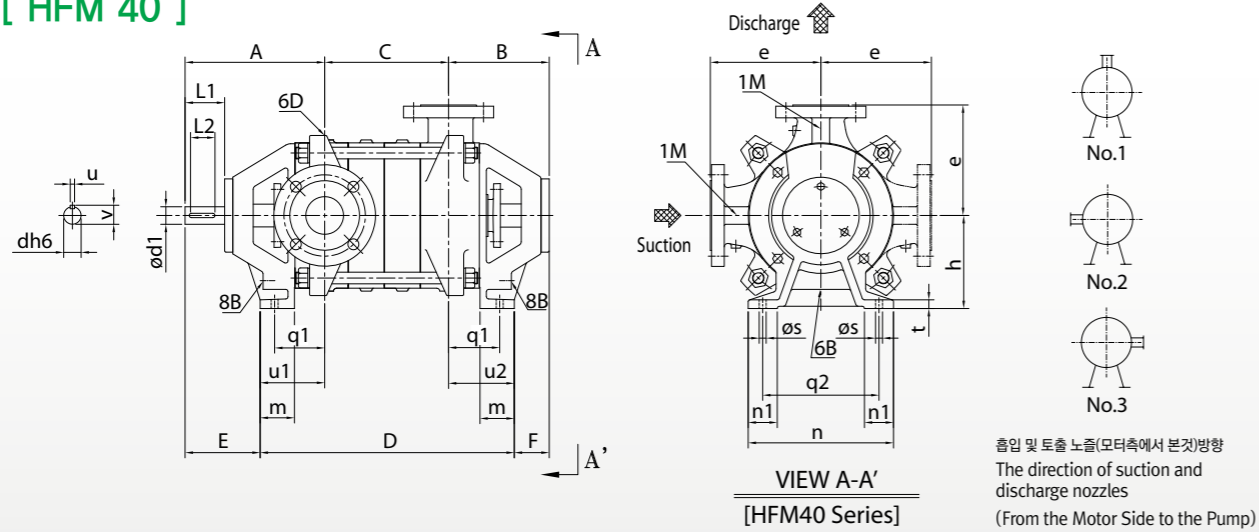

※ 주의

- 표준 플랜지 방향
• 흡입측 : No. 3 오른쪽 수평방향
• 토출측 : No. 1 수직방향 (TOP)
- 비표준 플랜지는 별도 제작하며
가격 추가 및 제작기간 별도 고려

※ Note

- Standard Flange Direction
• Suction : No. 3 right horizontal
• Discharge : No. 1 vertical (top)
- Non-standard flanges can be manufactured.
Additional costs and periods should be considered

Symbol	Connection Purpose	Size	Remarks
1M	Vacuum & Pressure Gauge	PT 3/8"	
6B	Casing Drain	PT 3/8"	
6D	Vent & Priming	PT 3/8"	
8B	Leakage Drain	PT 3/8"	

[HFM 50/65/80/100/125/150/200]

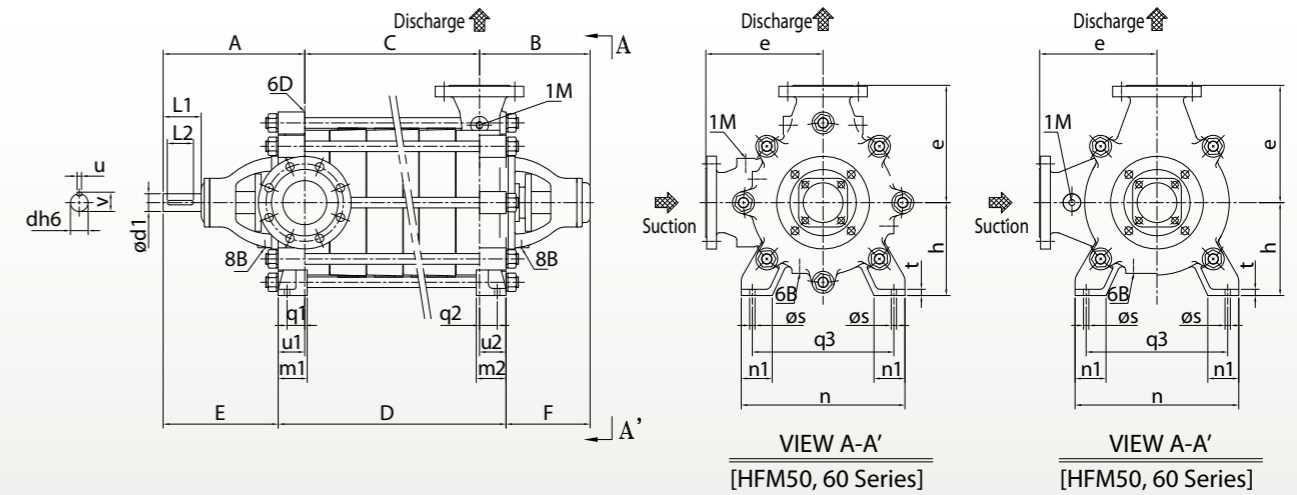

Symbol	Connection Purpose	HFM50, 65	HFM80, 100, 125, 150, 200	Remarks
1M	Vacuum & Pressure Gauge	PT 3/8"	PT 3/8"	
6B	Casing Drain	PT 3/8"	PT 1/2"	
6D	Vent & Priming	PT 3/8"	PT 1/2"	
8B	Leakage Drain	PT 1/2"	PT 1/2"	

Unit : mm

Model	Type	흡입 구경 Suc.	토출 구경 Dis.	Pump Dimension													Shaft Dimension							
				A	B	D	E	F	e	h	m	n	n1	q1	q2	s	t	u1	u2	d1 j6	L1	L2	v	u
HFM	40	50	40	231	161	C+208	127	127	174	160	60	224	65	175	80	14	14	104	104	25	69	45	28	8

※ All Stainless Pump Dimension 별도 문의 요망

Unit : mm

Model	Type	흡입 구경 Suc.	토출 구경 Dis.	단수에 따른 치수 "C" Dimension "C" by No. of Stages											
				1 2 3 4 5 6 7 8 9 10 11 12											
				1	2	3	4	5	6	7	8	9	10	11	12
HFM	40	50	40	78	133	188	243	298	353	408	463	518	573	628	683

Unit : kg

Model	Type	흡입 구경 Suc.	토출 구경 Dis.	단수에 따른 펌프 무게 (GC200 기준) Pump Weight by No. of Stages (for GC200)											
				1 2 3 4 5 6 7 8 9 10 11 12											
				1	2	3	4	5	6	7	8	9	10	11	12
HFM	40	50	40	63	72	81	90	99	108	117	126	135	144	153	162

Unit : mm

Model	Type	흡입 구경 Suc.	토출 구경 Dis.	Pump Dimension													Shaft Dimension									
				A	B	D	E	F	e	h	m1	m2	n	n1	q1	q2	q3	s	t	u1	u2	d1 j6	L1	L2	v	u
HFM	50	65	50	270	223	C+120	210	235	190	210	53	60	350	75	33	40	280	16	14	53	60	30	72	45	33	8
	65	80	65	282	242	C+128	218	246	215	220	64	64	370	75	39	39	300	16	14	64	64	35	75	50	38	10
	80	100	80	330	261	C+135	262	282	275	225	60	60	400	70	40	40	340	16	14	60	60	40	88	75	43	12
	100	125	100	360	276	C+140	290	379	320	285	70	70	510	80	45	45	420	16	14	70	70	45	103	80	48.5	14
	125	150	125	420	300	C+170	335	335	375	300	85	85	550	95	50	51	460	20	18	85	85	50	125	90	53.5	14
	150	200	150	490	355	C+200	390	400	425	350	110	100	650	110	65	65	550	24	18	110	100	60	140	90	64	18
200	250	200	550	387	C+265	409	419	470	400	140	140	770	140	79	79	640	28	20	140	140	70	167	120	74.5	20	

※ All Stainless Pump Dimension 별도 문의 요망

Unit : mm

Model	Type	흡입 구경 Suc.	토출 구경 Dis.	단수에 따른 치수 "C" Dimension "C" by No. of Stages																
				2 3 4 5 6 7 8 9 10																
				2	3	4	5	6	7	8	9	10								
HFM	50	65	50	164	235	305	376	446	517	587	-	-	-	-	-	-	-	-	-	-
	65	80	65	190	269	348	427	506	585	664	-	-	-	-	-	-	-	-	-	-
	80	100	80	221	319	416	514	611	709	-	-	-	-	-	-	-	-	-	-	-
	100	125	100	252	360	469	577	686	-	-	-	-	-	-	-	-	-	-	-	-
	125	150	125	280	395	510	625	-	-	-	-	-	-	-	-	-	-	-	-	-
	150	200	150	360	505	650	-	-	-	-	-	-	-	-	-	-	-	-	-	-
200	250	200	423	584	-	-	-	-	-	-	-	-	-	-	-	-	-	-	-	

Unit : kg

Model	Type	흡입 구경 Suc.	토출 구경 Dis.	단수에 따른 펌프 무게 (GC200 기준) Pump Weight by No. of Stages (for GC200)															
				2 3 4 5 6 7 8 9 10															
				2	3	4	5	6	7	8	9	10							
HFM	50	65	50	112	131	150	169	188	207	226	-	-	-	-	-	-	-	-	-
	65	80	65	142	168	195	221	248	274	301	-	-	-	-	-	-	-	-	-
	80	100	80	200	239	278	317	356	395	-	-	-	-	-	-	-	-	-	-
	100	125	100	301	366	434	498	564	-	-	-	-	-	-	-	-	-	-	-
	125	150	125	390	460	530	600	-	-	-	-	-	-	-	-	-	-	-	-
	150	200	150	670	795	920	-	-	-	-	-	-	-	-	-	-	-	-	-
200	250	200	960	1195	-	-	-	-	-	-	-	-	-	-	-	-	-	-	